

INTERNAL WIRE GUIDE | INSTALLATION INSTRUCTIONS

STEP 1. - INSTALL TENSION STOPPER USING CORRECT SCREWS

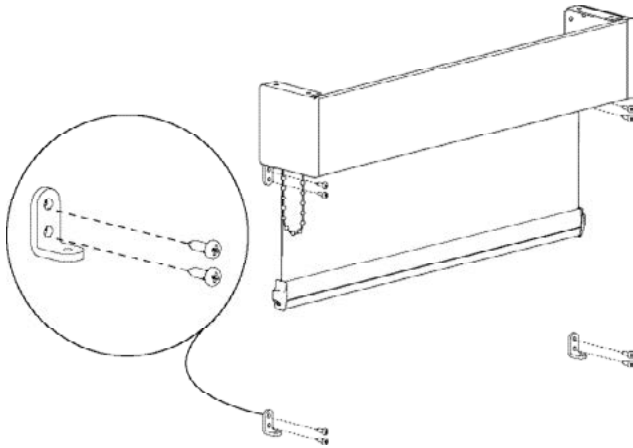

STEP 2. - SCREW THE TENSION ADJUSTER TO THE TENSION STOPPER

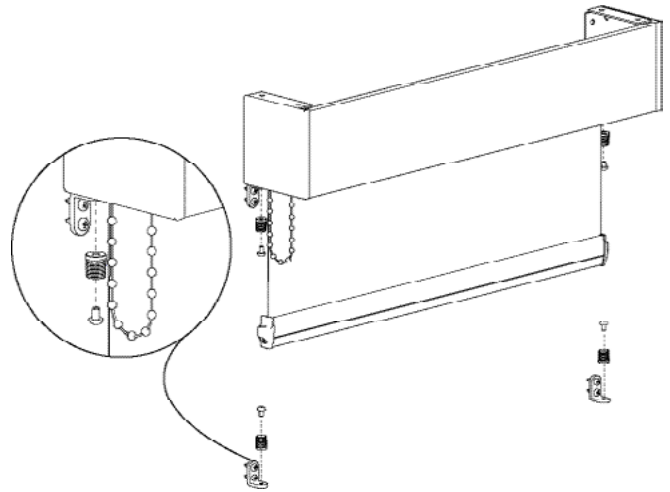

STEP 3. - CUT THE WIRE USING A WIRE CUTTER

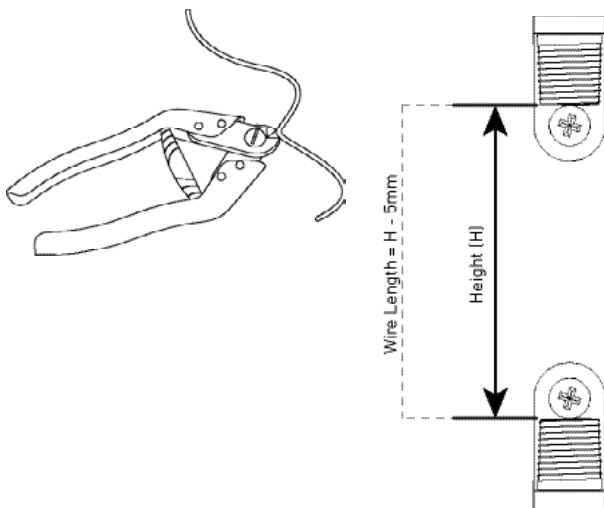

STEP 4. - PASS THE WIRE THROUGH THE TENSION ADJUSTER COVER AND CRIMPING CLIP

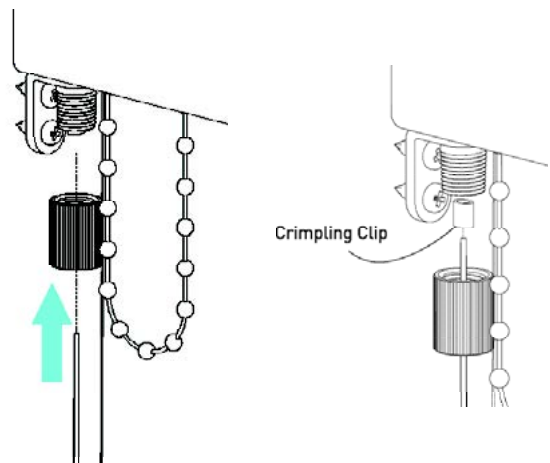

STEP 5. - CRIMP THE TOP CLIP USING A CRIMPING TOOL

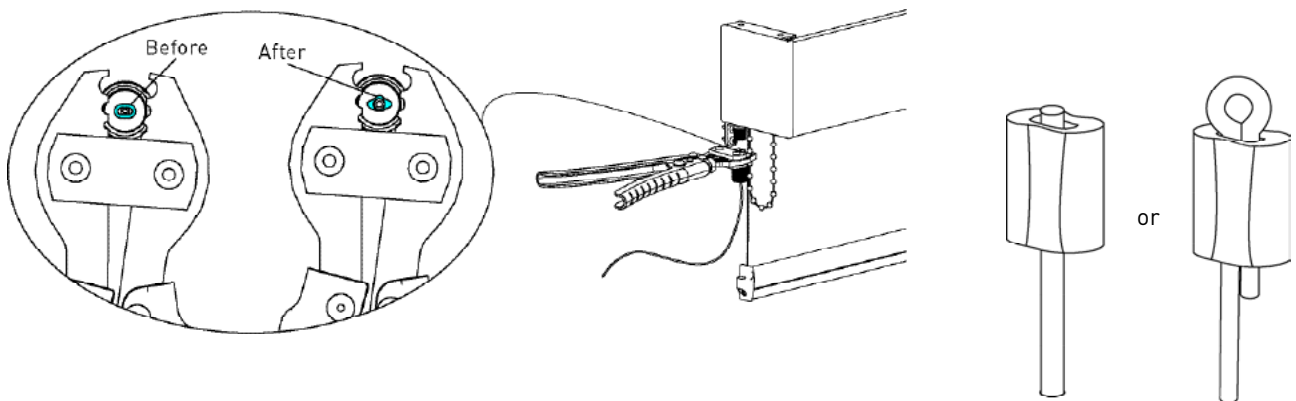

*If the wire is not looped, Wire Length = $H - 5\text{mm}$

**If the wire is looped, Wire Length = $H + 25\text{mm}$

STEP 6. - ROTATE THE TENSION ADJUSTER COVER IN CLOCKWISE DIRECTION (MINIMUM 2 TURNS)

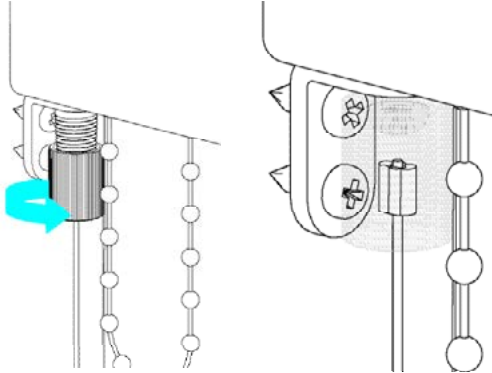

STEP 7. - PASS THE WIRE THROUGH THE BOTTOM RAIL WIRE GUIDE END CAP

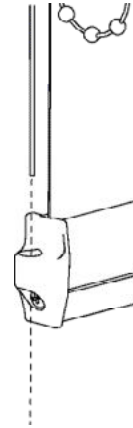

STEP 8. - PASS THE WIRE THROUGH THE TENSION ADJUSTER COVER AND CRIMPING CLIP



STEP 9. - CRIMP THE BOTTOM CLIP USING A CRIMPING TOOL

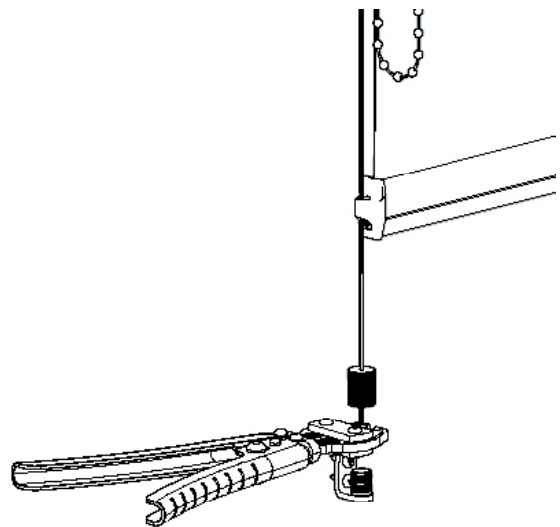

STEP 10. - ROTATE THE TENSION ADJUSTER COVER IN CLOCKWISE DIRECTION

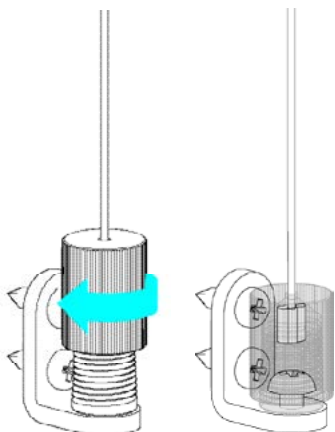

STEP 11. - ADJUST THE WIRE TENSION BY ROTATING THE TOP AND BOTTOM TENSION ADJUSTER COVERS

